



# IM60 Series Photovoltaic Modules



Peak Power: 230-245Wp

## Features

- 60 MOTECH multicrystalline solar cells connected in series
- Designed for 600V or 1000V applications
- For commercial or residential grid-tied applications
- Output power tolerance of -3% +5%
- Robust, anodized aluminum frame and tempered glass
- Tyco junction box, easy-click SOLARLOK<sup>®</sup> connectors, and cable
- Global manufacturing and world-class quality

**POWERED BY**  
**MOTECH**  
**SOLAR CELLS**

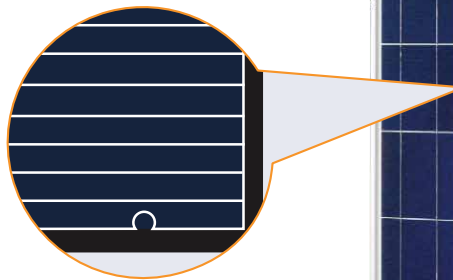

## Quality, Reliability, and Yield

Motech modules are powered by some of the highest performance and most reliable silicon cells in the solar industry. Motech modules are engineered and tested to the highest possible quality standards and are recognized throughout the world for their ability to deliver lifetime performance and, most importantly, maximized kWh yield.

## 25-Year Extended Warranty\*

- 10-year warranty at 90%; 25-year warranty at 80%
- 5-year warranty on materials and workmanship

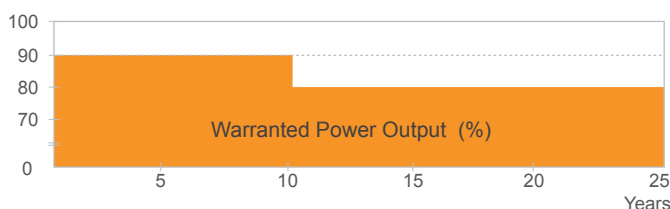

## Certifications & Standards\*



IEC 61215  
IEC 61730



UL 1703  
CEC listed



Application Class A  
Safety Class II

\* Please refer to our website for certification and warranty details.

# IM60 Series Photovoltaic Modules



## Physical Characteristics

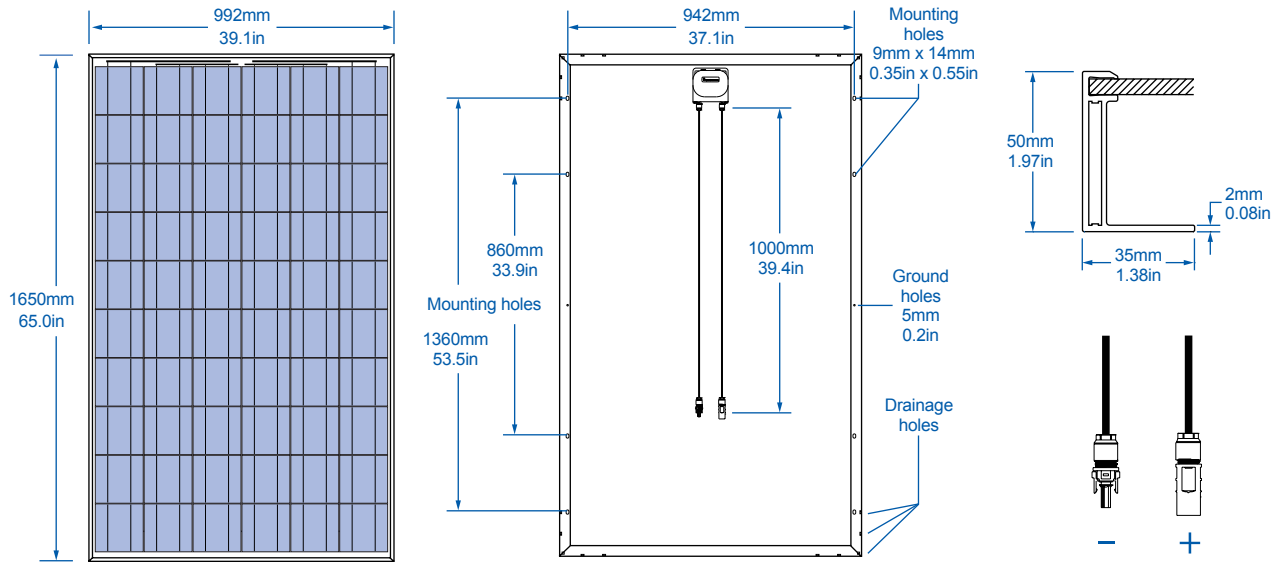

## Physical Design Properties

Weight	43.7 lb [19.8 kg]
Maximum Tested Load	±50 psf [2400 Pa] / +113 psf [5400 Pa] *
Hailstone Impact Resistance	1" @ 50 mph [25 mm @ 80 kph]
Junction Box	IP65 rated
Output Cables	4.0mm <sup>2</sup> Universal PV Wire, 1000mm [39.4in], Tyco SOLARLOK® Connectors

\*Refer to module installation instructions for maximum loading configurations.

## IV Curve

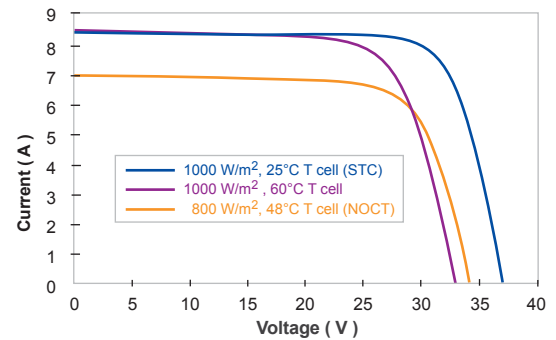

## Electrical Performance

Module Model Number	MTPVp-230-MSC	MTPVp-235-MSC	MTPVp-240-MSC	MTPVp-245-MSC				
Peak Power Pmax(Wp)	230	235	240	245				
Test Conditions	STC	NOCT	STC	NOCT	STC	NOCT	STC	NOCT
Max. Power Voltage Vmpp(V)	29.1	26.4	29.4	26.6	29.8	27.0	29.9	27.1
Max. Power Current Imp(A)	7.9	6.3	8.0	6.4	8.1	6.5	8.2	6.5
Open Circuit Voltage Voc(V)	36.8	33.8	37.1	34.1	37.3	34.2	37.4	34.3
Short Circuit Current Isc(A)	8.4	6.8	8.5	6.9	8.6	7.0	8.7	7.1

## Electrical Performance Parameters

Isc Temperature Coefficient	$\alpha$ (%/°C)	+0.07 ±0.02	Max. Series Fuse	15A
Voc Temperature Coefficient	$\beta$ (%/°C)	-0.34 ±0.01	Max. System Voltage	600V, 1000V
Pmax Temperature Coefficient	$\gamma$ (%/°C)	-0.46 ±0.02	Normal Operating Cell Temp. (NOCT)	48°C ± 2°C
Efficiency Reduction at 200W/m <sup>2</sup> , 25°C		<5%	Limiting Reverse Current (Ir)	8.7A

IV parameters are rated at Standard Test Conditions (Irradiance of 1000 W/m<sup>2</sup>, AM 1.5, cell temperature 25°C). All measurements are guaranteed at the laminate leads. NOCT is measured at 800 W/m<sup>2</sup>, 20°C ambient, and 1 m/s windspeed. Specifications are subject to change without notice. Motech reserves the rights of final interpretation and revision on this datasheet.

MA000600 Rev C, March, 2011

MOTEC INDUSTRIES, INC.

www.motech-americas.com

MOTEC Americas LLC, a division of MOTEC Industries, Inc.

231 Lake Drive, Newark, Delaware 19702 USA

Tel: +1-302-451-7500 | E-mail: modules@motech-americas.com